

NARROW CORRUGATION (2.66" - 6.76 CM) SEVEN (7) FOOT DIA. HOPPER BOTTOM BIN ASSEMBLY AND INSTALLATION INSTRUCTIONS AND REPAIR PARTS LIST

MODEL NO.	DESCRIPTION	CAPACITY *
BB701	7 Ft. (2.13 Meters) Dia. / One 32"(81.3 cm) Ring	4.6 (4.2)
BB702	7 Ft. (2.13 Meters) Dia. / Two 32" (81.3 cm) Rings	6.7 (6.1)
BB703	7 Ft. (2.13 Meters) Dia. / Three 32" (81.3 cm) Rings	8.7 (7.9)
BB704	7 Ft. (2.13 Meters) Dia. / Four 32" (81.3 cm) Rings	10.8 (9.8)

* Capacity is in 2000 pound tons & (metric tons). For additional specifications, see page 20 and 21.

WHEN ORDERING PARTS

- (1) Show MODEL NUMBER and NAME: Example - BB701 7 Ft. Dia. Hopper Bottom Bin.
- (2) Show PART NUMBER and FULL DESCRIPTION of part: Example - 907-0051 Caulking.

HOW TO ORDER PARTS

Repair parts may be ordered from your dealer.

TABLE OF CONTENTS

Table of Contents.....	1
Introduction and Safety.....	2, 3
Foundations.....	4
Anchoring.....	4
General Information & Hardware Usage.....	5, 6
Hardware Descriptions & Bolt Head Placement.....	7
7' dia. Assembly Instructions.....	8-19
Top Body Ring.....	8
Roof & Collar.....	9, 10
Lower Body Rings.....	11
Hopper & Collar.....	12-14
Legs.....	15, 16
Bracing.....	16, 17
Ladder Assembly.....	18
Setting Bin Upright.....	19
Securing the Bin to the Foundation.....	19
Bin Grounding.....	20
Chart of Capacities.....	20
Height Specifications.....	21
Bill of Materials/Repair Parts List.....	22, 23
Field Modification and Maintenance.....	24



PO BOX 2000, HOUGHTON, IOWA 52631 USA
PHONE 319-469-4141 • FAX 319-469-4402

ISHBB701
PRINTED IN U.S.A.

INTRODUCTION AND SAFETY

Thank you for purchasing your hopper bottom bin from Hawkeye Steel Products, Inc. (HSPI)

Check the materials received against the packing list to ensure all materials are present.

Read all safety information and instructions thoroughly **BEFORE** starting construction. **SEE SAFETY CONSIDERATIONS AND SEE BIN GROUNDING ON PAGE 20.**

Optional equipment contains necessary assembly and operation instructions.

Choose the site for your bin carefully. Leaving space for future expansion is a prime consideration. The soil of your bin site should have a uniform load bearing capacity of at least 3500 pounds-per-square-foot (about 17,100 kilograms per square meter) and have good drainage.



**Bin installations must meet all applicable local and national codes.
Check with the proper authorities before beginning installation.
Bin must be grounded. See page 20.**

READ ALL DIRECTIONS CAREFULLY BEFORE BEGINNING INSTALLATION



Read and follow all safety precautions for any power tools to be used during this installation! Failure to follow these safety precautions could result in electrical shock or serious injury causing disfigurement or death!

Safety is just as important as the productivity of your bin. This section serves as a guide to help and encourage a safe operation. However, it is your responsibility to evaluate each operation and to determine and implement the best method of protecting yourself as owner and/or operator. Establish and promote a program of safety that assures safe working practices.

CONSTRUCTION SAFETY

1. Low spots that could collect water should be eliminated so as not to come in contact with electric cords used in construction.
2. Ground all electrical equipment.
3. In planning the location, take into consideration any areas that could present an unsafe situation. Avoid power lines that could come in contact with bin.
4. Keep safety guards on equipment.
5. Wear eye protection when using drills or saws on equipment causing flying debris.
6. Wear hard hats during construction.
7. Plan a way to secure tools, parts, and equipment when working above others.
8. Take care not to lift items too heavy. Avoid back and muscle injury.

PRE-OPERATION SAFETY

1. Check electrical performance and lock outs on equipment.
2. Check again for unsafe areas and be sure all are identified with warning labels.

OPERATION SAFETY

1. Do not enter hopper bin during operation.
2. Never enter bin with bridged material
3. Read and re-read all warning labels.
4. Be absolutely sure electricity is locked out when working with or near moving parts.
5. Do not bypass electrical safety equipment. Make sure electrical equipment is properly installed and grounded by a qualified electrician.
6. Keep all extremities away from moving parts.
7. Be sure guards and safety devices are correctly installed and in proper position.
8. Call HSPI before making field modifications to make sure the changes do not alter strength and/or safety of the bin.
9. Know who or where to call for immediate help in the event of an emergency or injury.
10. Keep area around bin free of clutter and debris.

DANGER



YOU CAN SUFFOCATE UNDER GRAIN IN THIS BIN



DO NOT ENTER WHEN THIS BIN IS BEING LOADED OR UNLOADED.

— IF YOU MUST ENTER THE BIN —

1. SHUT OFF AND LOCK OUT ALL POWER.
2. USE A SAFETY HARNESS AND SAFETY LINE.
3. WEAR A DUST RESPIRATOR.
4. AVOID THE CENTER OF THE BIN.
5. STATION A PERSON TO HELP FROM OUTSIDE THE BIN.

— THE DANGER IS FROM —

<p>FLOWING GRAIN</p>  <p>FLOWING GRAIN TRAPS AND SUFFOCATES</p>	<p>AND</p>	<p>CRUSTED GRAIN</p>  <p>CRUSTED GRAIN COLLAPSES AND SUFFOCATES</p>
--	------------	---

FOUNDATIONS

Foundations— must be placed on soil with a uniform load bearing capacity of 3500 pounds-per-square-foot (about 17,100 kilograms per square meter), or special foundations must be considered. Contact a qualified soil engineer to answer any questions you may have.

- Foundations must be designed per local soil and frost depth conditions.
- Foundations must be smooth and level.

Concrete in footings must have a minimum compressive strength of 3000 pounds-per-square-inch (about 211 kilograms per square centimeter).

Concrete reinforcing shall have a minimum yield strength of 33,000 pounds-per-square-inch (about 2320 kilograms per square centimeter).

Anchor bolt dimensions are the same for square or round foundations. Dimensions are in inches (centimeters).

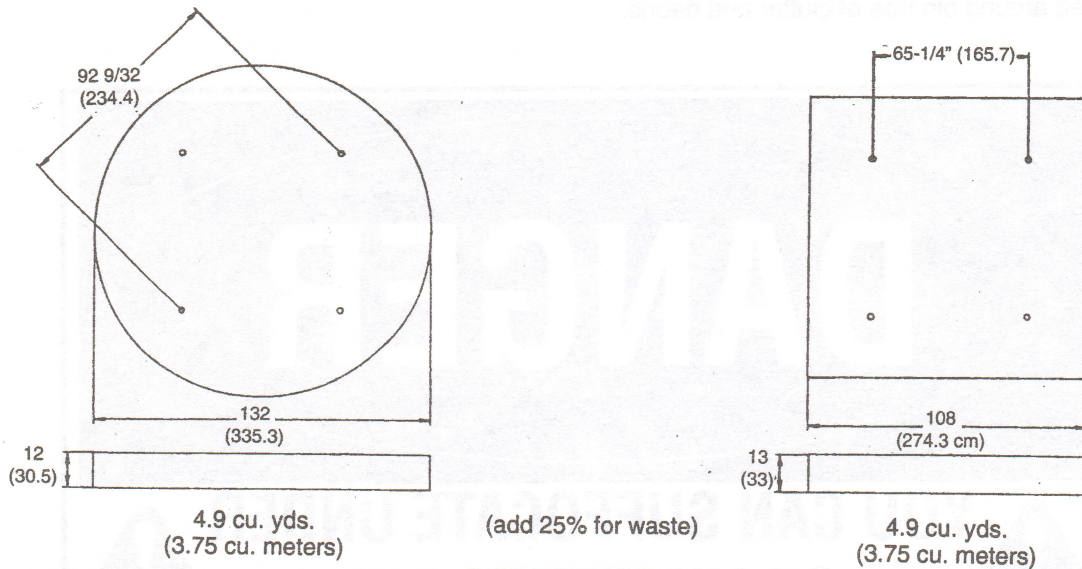

ANCHORING

Use a 5/8" dia. (1.6 cm) x 8" (20.3 cm) x 2" (5.1 cm) 'L'-Bolt with a required embedded depth of 6-1/2" (16.5 cm).

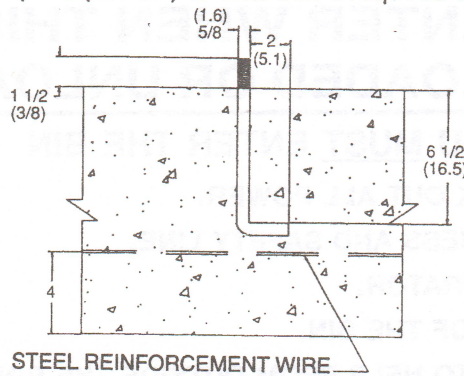

ALTERNATIVE ANCHORING

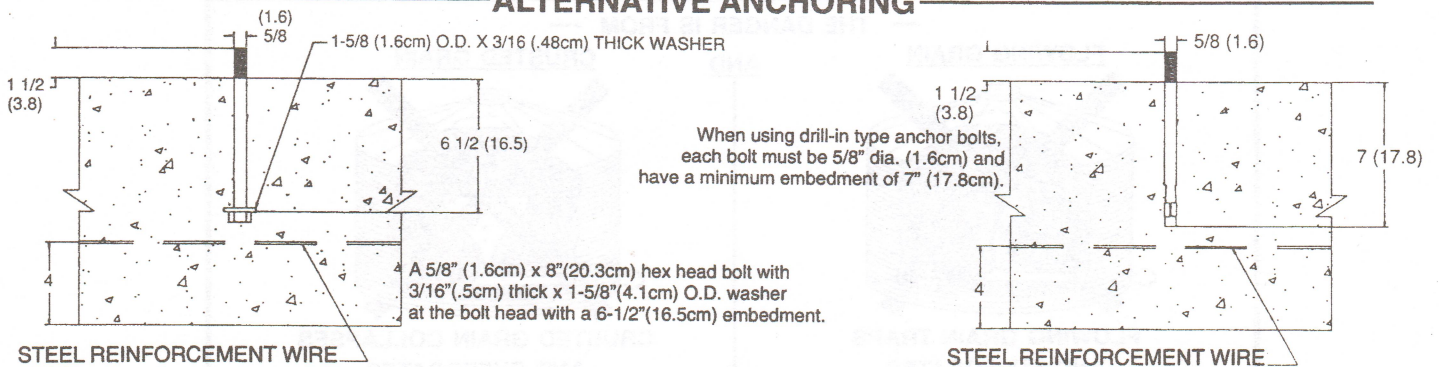

GENERAL INFORMATION & HARDWARE USAGE

1. Bolt hole spacing at the top and bottom of the bottom body ring, and at the top of any additional rings, is 2-11/32" (5.95cm). Bolt hole spacing at the bottom of upper body rings is 9-3/8" (23.8cm).
2. Overlap vertical body ring seams in the same direction. (See EXHIBIT C, page 8). Install each consecutive upper body ring to the inside of the ring above it, and stagger overlapping vertical body seams (See EXHIBITS H & I, page 11).
3. **NOTE FASTENER USAGE BELOW AND ALSO SEE EXHIBIT A.**

Location	Type of Fastener	Bolt Head on the
Roof to Collar	5/16" x 3/4" (.8 cm x 1.9cm) truss head/hex flange nut	outside
Vertical Roof Seams (non-ladder reinforcement)	5/16" x 3/4" (.8 cm x 1.9cm) hex head/hex nut	outside
Vertical Roof Seams (2 seams where ladder reinforcement angles are located)	5/16" x 1 1/4" (.8 cm x 3.2cm) hex head/hex nut	outside
Roof to Body	5/16" x 1 1/4" (.8 cm x 3.2cm) hex head/hex nut	outside
Vertical Body Seams	5/16" x 1 1/4" (.8 cm x 3.2cm) hex head/hex nut	outside
Horizontal Body Seams	5/16" x 1 1/4" (.8 cm x 3.2cm) hex head/hex nut	outside
Hopper to Body	5/16" x 1 1/4" (.8 cm x 3.2cm) hex head/hex flange nut	outside
Vertical Hopper Seams	5/16" x 3/4" (.8 cm x 1.9cm) truss head/hex flange nut	inside
Hopper to Collar	5/16" x 3/4" (.8 cm x 1.9cm) truss head/hex flange nut	inside
Collar to Plastic Transition	5/16" x 3/4" (.8 cm x 1.9cm) truss head/nylon nut	inside
Hopper Brace to Collar	5/16" x 3/4" (.8 cm x 1.9cm) truss head/hex flange nut	inside
Hopper Brace to Leg	5/16" x 3/4" (.8 cm x 1.9cm) truss head/hex flange nut	outside
Leg to Body	5/16" x 1 1/4" (.8 cm x 3.2cm) hex head/hex nut	inside
Leg Tie Bracing	5/16" x 1 1/4" (.8 cm x 3.2cm) hex head/hex nut	outside
Leg 'x' Bracing	5/16" x 3/4" (.8 cm x 1.9cm) hex head/hex nut	outside

4. **IMPORTANT– DO NOT TIGHTEN ANY BOLTS MORE THAN FINGER TIGHT UNTIL SPECIFIED!! BOLTS ARE ALWAYS TIGHTENED FROM THE NUT SIDE ONLY (except where noted) TO PREVENT DAMAGE TO THE RUBBER SEALS.**

NOTICE		
Bin bolts must be <u>tight</u> . The following table contains recommended minimum and maximum torque values:		
Bolt Diameter	Torque (Ft. - Lbs.)	
5/16" (.8 cm)	Minimum	Maximum
	14	18
Tighten bin bolts from the nut end of bolt to eliminate "spin-off" of sealing washer.		
Use only those bolts supplied by the bin manufacturer. The substitution of bolts from other sources is not permitted.		

5. Please refer to the diagrams on page 7 for hardware descriptions and bolt head placement.

6. Roof & Hopper Sheet identification(7' Bin)

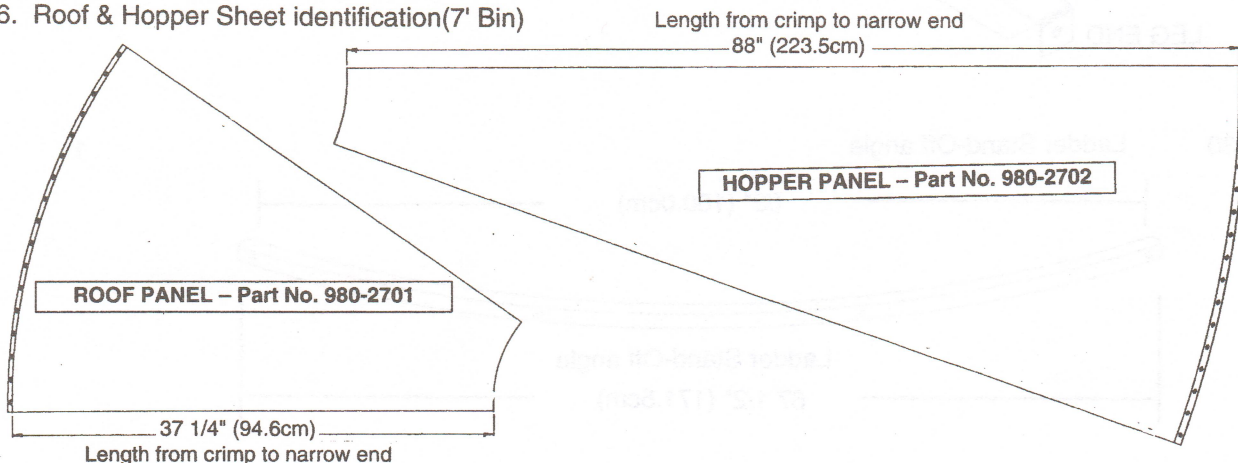

7. Angle Identification (7' Bin)

Part No.	Description	Length	Quantity
980-2711	Long Leg Tie Brace The long leg tie braces attach to the 2 legs closest to the ladder and then on the opposite side	63" (160.0cm)	4

980-2710	Short Leg Tie Brace	61 1/4" (155.6cm)	4
----------	---------------------	-------------------	---

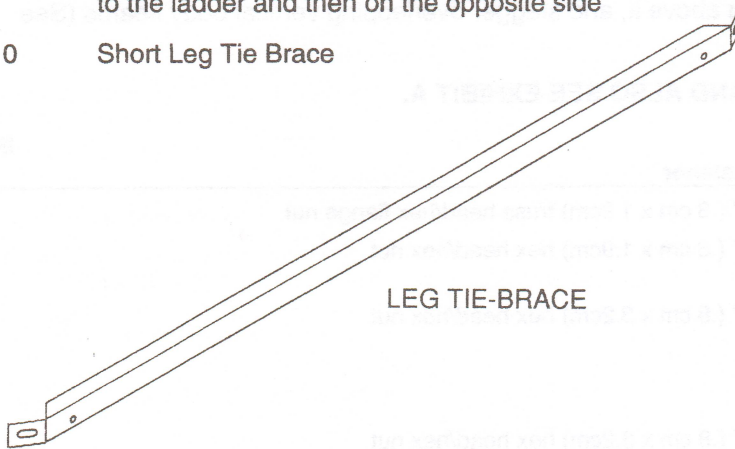

980-2609	Leg 'X' Brace	61 1/2" (156.2cm)	8
----------	---------------	-------------------	---

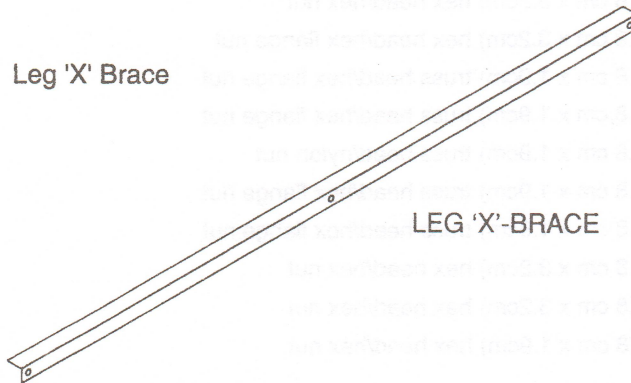

980-2704	Leg to Collar Brace	38 1/2" (114.3cm)	4
----------	---------------------	-------------------	---

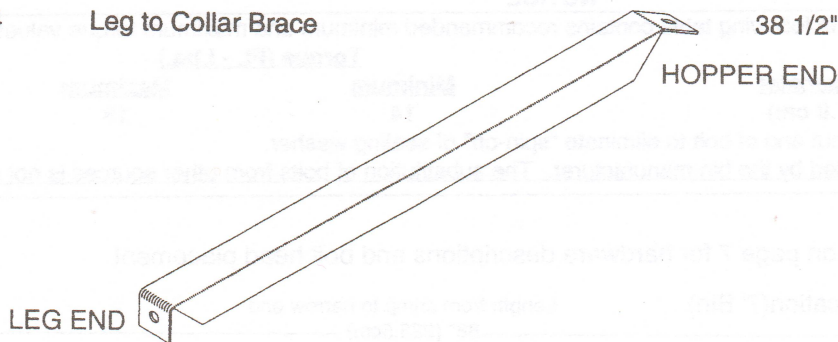

989-2330	Ladder Stand-Off angle		1
----------	------------------------	--	---

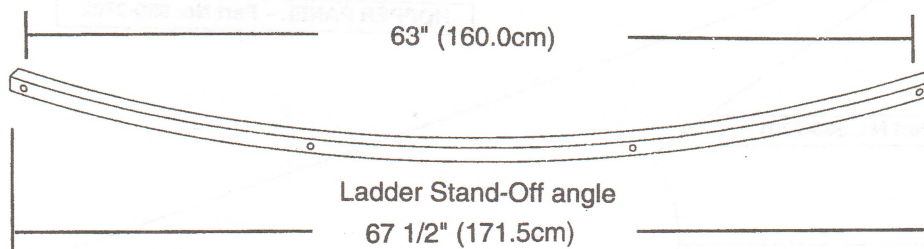

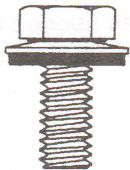
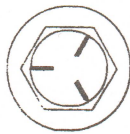

5/16-18 x 3/4 NC
(M8 x 1.25 x 20)
Hex Head Bolt
Grade-5 with
Rubber Backed Washer

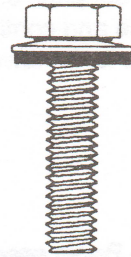
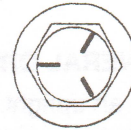

5/16-18 x 1-1/4 NC
(M8 x 1.25 x 30)
Hex Head Bolt
Grade-5 with
Rubber Backed Washer

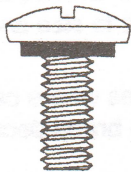
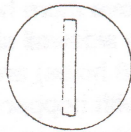

5/16-18 x 3/4 NC
(M8 x 1.25 x 20)
Slotted Truss Head
Machine Screw
Grade-8
with Neoprene-Seal



5/16-18 NC
(M8 x 1.25)
Hex Nut



5/16-18 NC
(M8 x 1.25)
Hex Flange Nut

BOLT HEADS OUTSIDE AT ROOF-TO-COLLAR,
ROOF PANEL-TO-PANEL, ROOF-TO-BODY,
HOPPER-TO-BODY, & VERTICAL BODY SEAMS

BOLT HEADS INSIDE AT
LEG-TO-BODY, HOPPER
PANEL-TO-PANEL, HOPPER-
TO-COLLAR, COLLAR-TO-
TRANSITION & HOPPER
BRACE- TO-COLLAR
CONNECTIONS

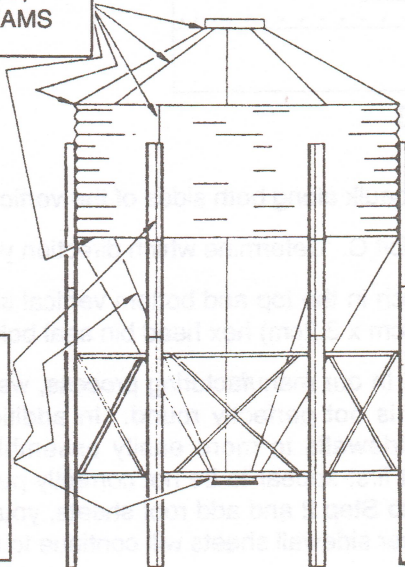

EXHIBIT A

5/16" = .8 cm 3/4" = 1.9 cm 1" = 2.54 cm 3/8" = .95 cm 1 1/4" = 3.18 cm 1 1/2" = 3.8 cm

ASSEMBLY

IMPORTANT! NOTE THE GENERAL ORDER OF ASSEMBLY

1. Assemble the top ring in an upright position.
2. Assemble the roof panels to top ring.
3. Assemble roof collar to roof panels.
4. Turn assembly on its side and continue to add sidewall sheets as needed for your size bin.
5. Assemble hopper panels to the lower sidewall sheets and assemble discharge collar to hopper panels.
6. Assemble legs.
7. Assemble leg bracing.
8. Assemble ladder.
9. Assemble lid opener.

TOP BODY RING – Begin assembly of your bin with the top sidewall sheets. In this step assemble the 2 top sidewall sheets **ONLY**.

If your bin has more than one ring, the top sidewall sheets will not have any vertical rows of holes for the legs. The edge up will have more horizontal holes than the edge down. If your bin has one ring only, the sidewall sheets will have an equal number of horizontal holes on both edges (58 holes) and will also have vertical leg holes. The edge that goes down (to mate with hopper sheets) has holes on the second row of corrugation. The edge that goes up has holes on the first (or outside) row of corrugation. All upper sidewall sheets on 2 ring, 3 ring and 4 ring nine foot diameter bins, are identical as to size and hole placement. See Exhibit D.

Stand the two top sheets on edge and wipe down areas where caulking is to be applied. One or both of these sheets should carry the brand decal.

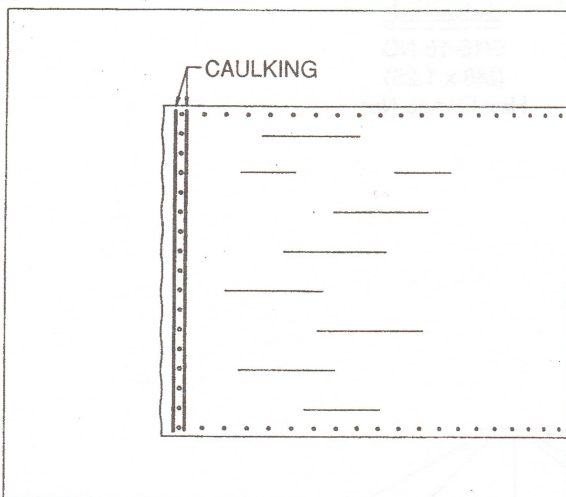
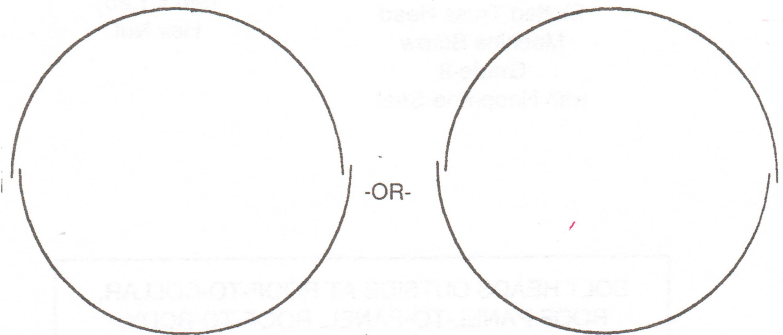

EXHIBIT B



MAINTAIN THE SAME OVERLAPPING PATTERN FOR ALL BODY RINGS

EXHIBIT C

Apply a bead of caulk along both sides of the vertical row of bolt holes. See Exhibit B.

Now review Exhibit C. Determine which direction you will be overlapping the body sheets.

Using a drift punch in the top and bottom vertical seam holes, bolt the vertical seams together, using 5/16" x 1 1/4" (.8cm x 3.2cm) hex head bin seal bolts with bolt heads on the outside.

PLEASE NOTE: In our manufacturing process, we may have side wall sheets that when assembled form a ring that is not perfectly round. In addition, our vertical holes are slightly tapered which permits lower sidewalls to more easily assemble to upper sidewalls. Thus, your top sidewall assembly may at first appear to be not correctly punched or to not have proper curvature. However, as you proceed to Step 2 and add roof sheets, your sidewalls will round out. Further, adding hopper panels to the lower sidewall sheets will continue to round out the sidewall assembly.

STEP 2:

ROOF PANELS – Take the top body ring you have just assembled and place ring on edge. See Step 1 and Exhibit D for which edge goes up. Always place the ladder over the seam of the top body ring. This is true on our 7 foot diameter bins only. Take a marker and mark as shown in Exhibit D. Write the word "Leg", "Roof", "Ladder" or use your own code.

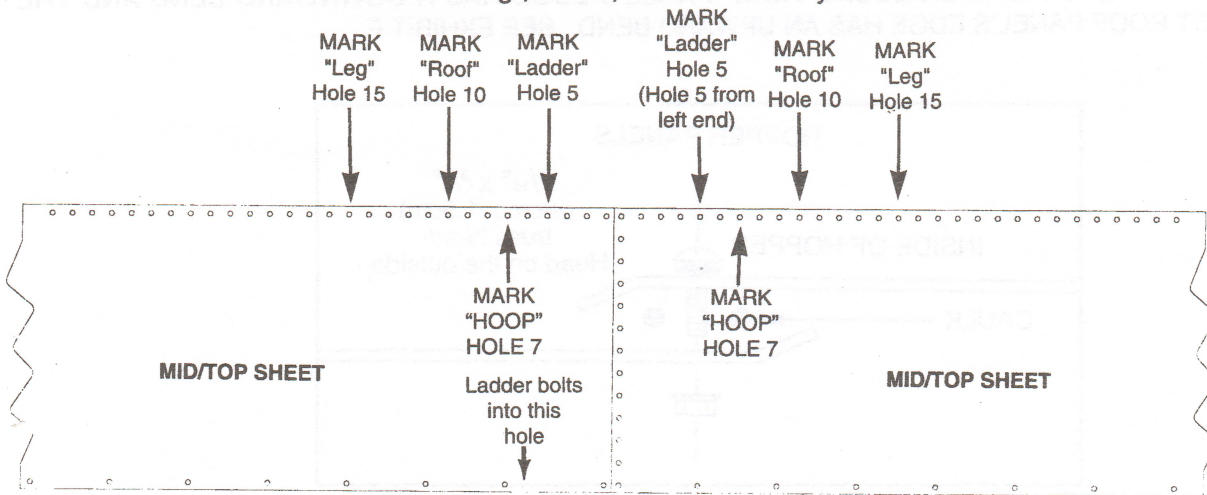
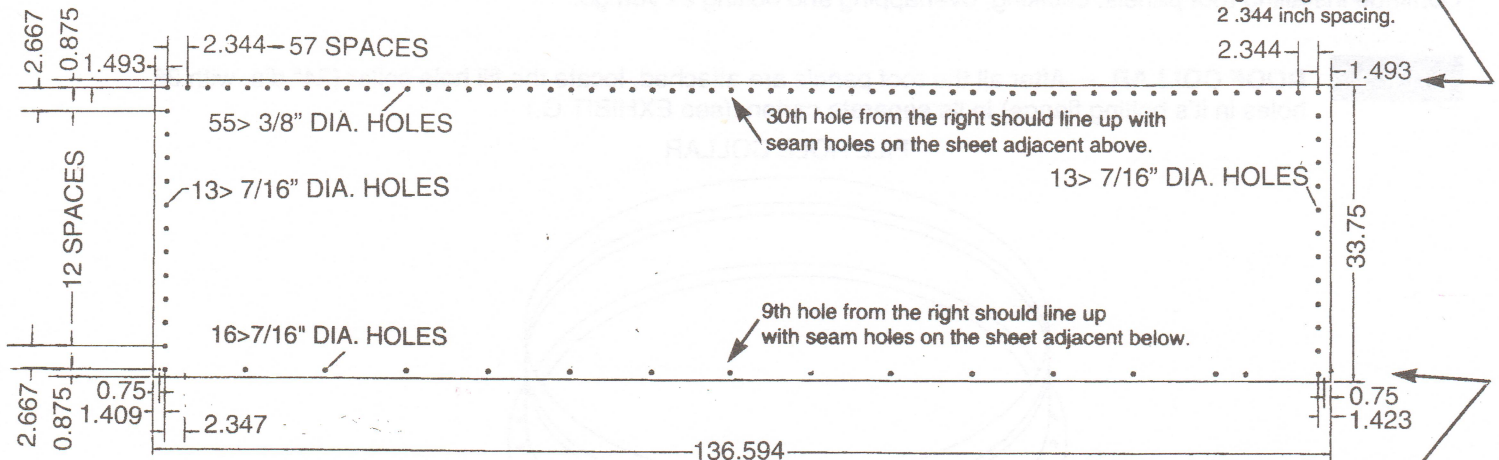

EXHIBIT D
Placement of Roof, Ladder, Leg, Hoop Components



Both upper and lower sidewall sheet have 58 holes on the edge that goes up -- 2.344 inch spacing.

EXHIBIT D (continued)
Mid/Top Sheet Hole Placement

Lower sidewall sheet has 58 holes on the second row of corrugation on the edge that goes down. Upper sidewall sheet has 16 holes on the edge that goes down, 9 3/8 inch spacing. NOTE, however the 2 holes spaced 2.347" apart in the lower right hand corner. The hole, second from right is for the ladder.

Wipe the outside of the top of each ring, as well as all roof panel seams and caulk on both sides of each row of holes before installation. See Exhibit E.

Place the first roof panel beginning in hole 10 as indicated in Exhibit D. Install the first panel using 5/16" X 1 1/4" (.8 cm x 3.2 cm) hex head bin seal bolts with heads on the outside. Do not put fasteners in the 2 holes marked "LADDER" - hole 25 and hole 33.

Do not tighten any roof or roof collar fasteners until instructed to do so in Step 3.

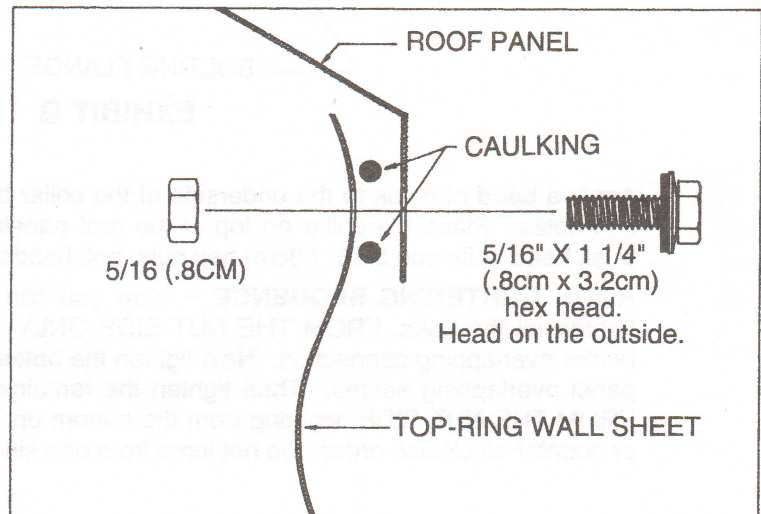

EXHIBIT E

After the first roof panel has been installed, begin installation of the second panel. Add 2 rows of caulk on both sides of the vertical roof panel holes. Use 5/16" x 3/4" (.8cm x 1.9cm) hex head bin seal bolts, heads on the outside.

NOTE: MAKE SURE THAT THE SECOND ROOF PANEL'S EDGE HAS A DOWNWARD BEND AND THE FIRST ROOF PANEL'S EDGE HAS AN UPWARD BEND. SEE EXHIBIT F.

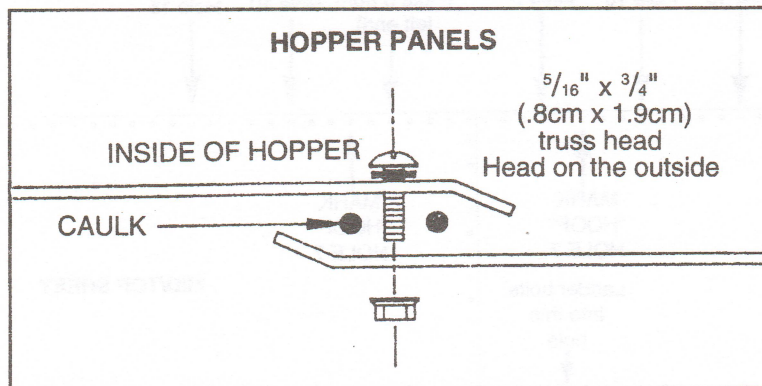

EXHIBIT F

Continue installing roof panels, caulking, overlapping and bolting as you go.

STEP 3: **ROOF COLLAR** – After all the roof panels are attached, locate the fill hole collar (24" dia. with 36 holes in it's bolting flange) in its separate carton. (see EXHIBIT G.)

FILL HOLE COLLAR

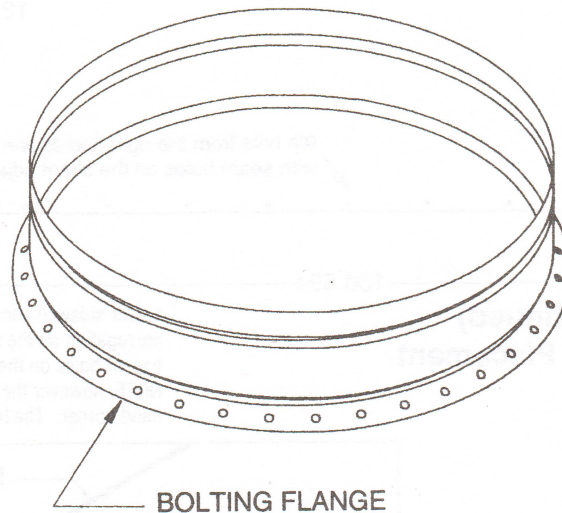
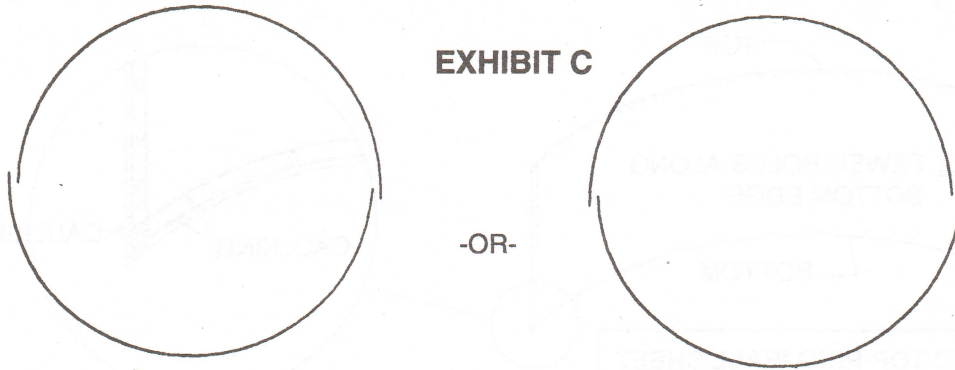

EXHIBIT G

Apply a bead of caulk to the underside of the collar bolting flange along both edges of the circle of bolt holes. Place the collar on top of the roof panels and install with 5/16" x 3/4" (.8cm x 1.9cm) truss head bolts and 5/16" (.8cm) hex nuts, bolt heads to the outside.

ROOF TIGHTENING SEQUENCE – Now you can begin tightening the bolts in the roof. First tighten all the bolts, **FROM THE NUT SIDE ONLY**, in the roof-to-body seam, including the body ladder overlapping connection. Next tighten the bottom four bolts, **FROM THE NUT SIDE**, in all roof panel overlapping seams. Then tighten the remaining bolts in the roof panel overlapping seams, **FROM THE NUT SIDE**, working from the bottom up. Tighten roof seams in consecutive clockwise or counter-clockwise order. Do not jump from one side of the bin to another.

STEP 4: SIDEWALL SHEETS – Turn the roof panel and upper sidewall assembly on its side. Continue to add sidewall sheets by following these directions. Determine which direction you will be overlapping the body sheets (see EXHIBIT C).



MAINTAIN THE SAME OVERLAPPING PATTERN FOR ALL BODY RINGS

Stagger the seams of sheets added below the top ring.

With a three or five ring bin, the vertical seams of the bottom sidewall sheets should align with the vertical seams of the upper most sidewall sheet.

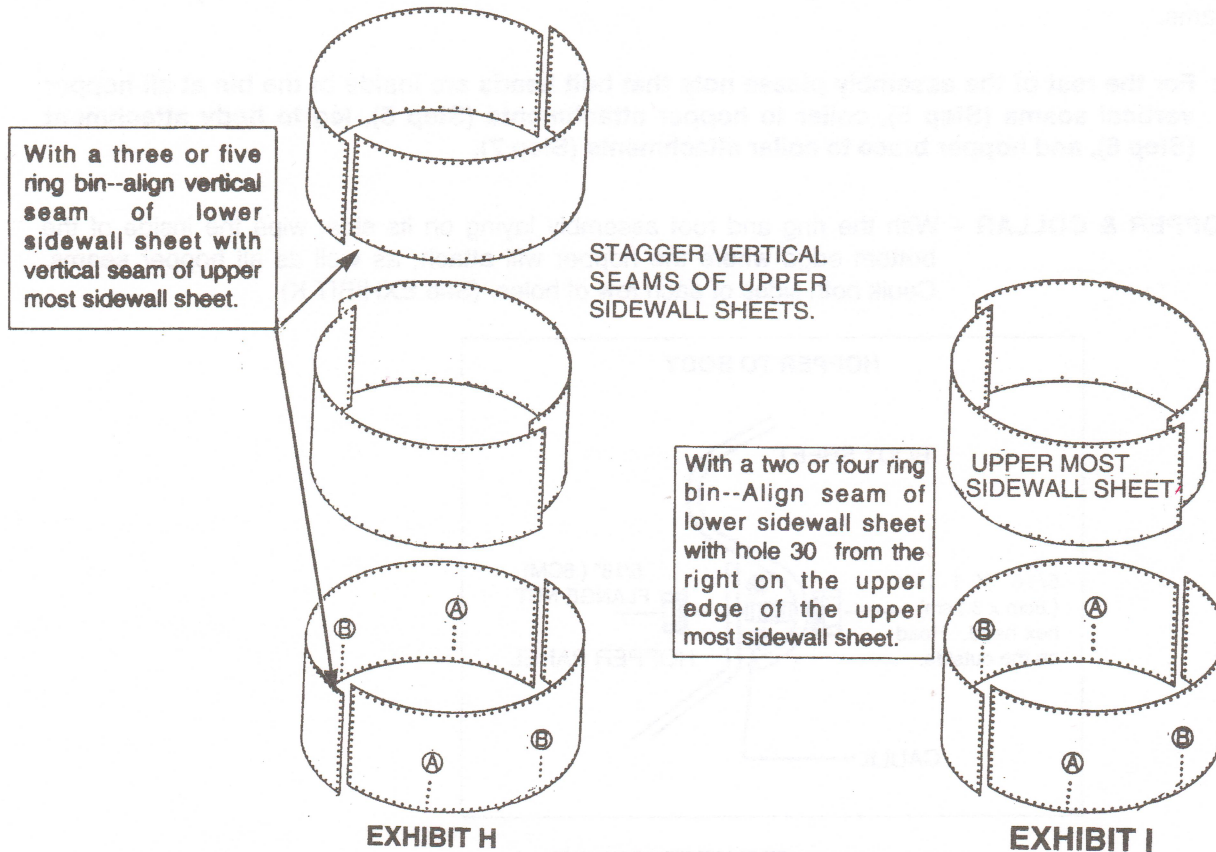

THE "A" ROW OF HOLES NEEDS TO BE DIRECTLY ACROSS FROM EACH OTHER AND LIKEWISE THE "B" ROW OF HOLES.

Before adding the first bottom sidewall sheet, please note: With a two or four ring bin, the first bottom sidewall sheet should start directly below hole 30 from the right of the upper most sidewall sheet. This allows legs on the opposite corner to be aligned with each other.

IMPORTANT! THE HORIZONTAL EDGE OF THE LOWER RING SHEETS GO UNDERNEATH THE HORIZONTAL EDGE OF THE UPPER RING SHEETS.

Wipe sidewall sheets along bolt holes.

Apply a bead of caulk along both edges of the line of bolt holes at the ends of the body sheets.

Also apply a bead of caulk along both edges of the vertical row of holes at each end of the second body-ring sheets. See EXHIBIT J

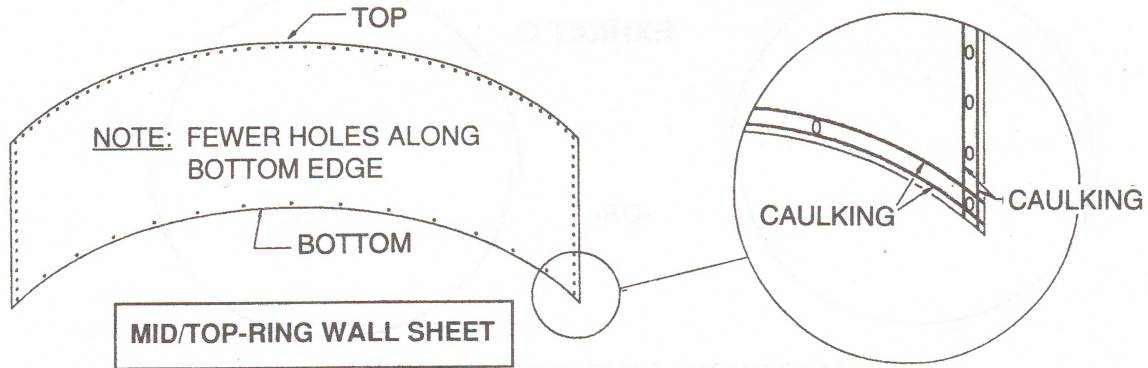

EXHIBIT J

Use an alignment punch to align holes. Horizontal body seams use 5/16" x 1 1/4" (.8cm x 3.2cm) hex head bin seal bolts. Vertical seams use 5/16" x 1 1/4" (.8cm x 3.2cm) hex head bin seal bolts. Bolt heads go on the outside of the bin. After all bolts are in place, tighten horizontal seams from the center of each body sheet out to the vertical seams.

IMPORTANT: For the rest of the assembly please note that bolt heads are inside of the bin at all hopper vertical seams (Step 5), collar to hopper attachments (Step 5), leg to body attachment (Step 6), and hopper brace to collar attachments (Step 7).

STEP 5: HOPPER & COLLAR – With the ring and roof assembly laying on its side, wipe the inside of the bottom edge where the hopper will attach, as well as all hopper seams. Caulk both sides of each row of holes. (See EXHIBIT K)

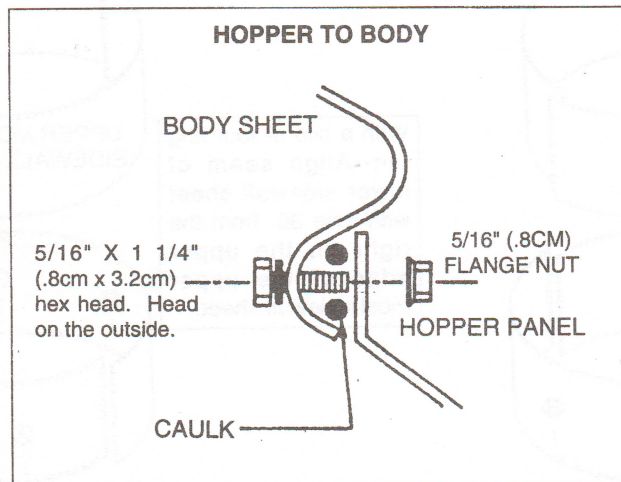

EXHIBIT K

Attach the first hopper panel so that the first hole in the crimped edge aligns with one of the bottom body rings vertical seams or with a set of mid-sheet leg holes (see EXHIBIT L). The hopper panels will attach to the inside of the body with 5/16" x 1 1/4" (.8cm x 3.2cm) bolts and 5/16" (.8cm) flange nuts, bolt heads on the outside.

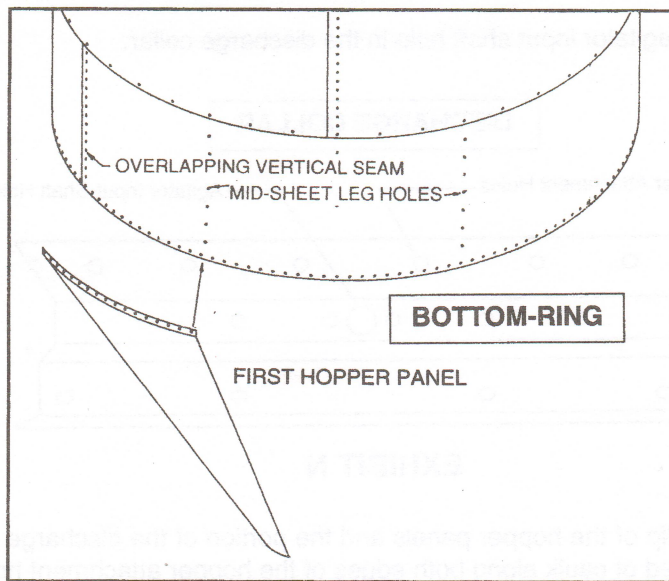

EXHIBIT L

Apply a bead of caulk along both sides of the row of holes in the long edge of the hopper panel that has the bend towards the outside of the bin. Install the second hopper panel, overlapping the caulked edge of the first, and attach with 5/16" x 1 1/4" (.8cm x 3.2cm) bolts and 5/16" (.8cm) flange nuts at the hopper-to-body seam. Align the bolt holes in the hopper vertical seams and install 5/16" x 3/4" (.8cm x 1.9cm) slotted truss head bolts and 5/16" (.8cm) flange nuts, bolt heads to the inside. See EXHIBIT M.

Continue installing hopper panels maintaining the same caulking and bolting pattern. However, DO NOT install the last hopper panel yet. DO NOT TIGHTEN FASTENERS YET.

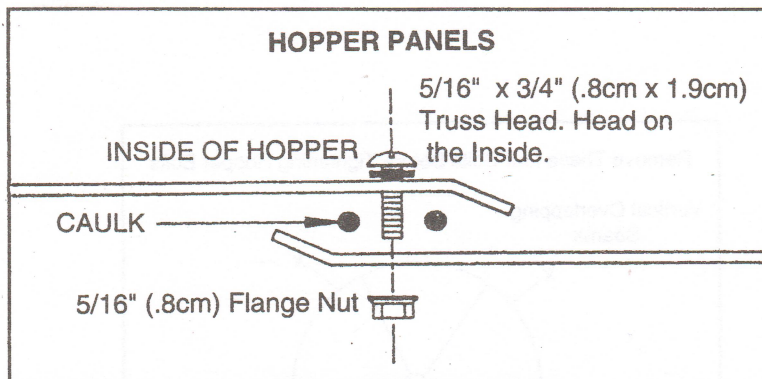

EXHIBIT M

DISCHARGE COLLAR INSTALLATION – At this time locate the discharge collar and mounting hardware. This is supplied in its own carton.

Note the location of the large agitator input shaft hole in the discharge collar.

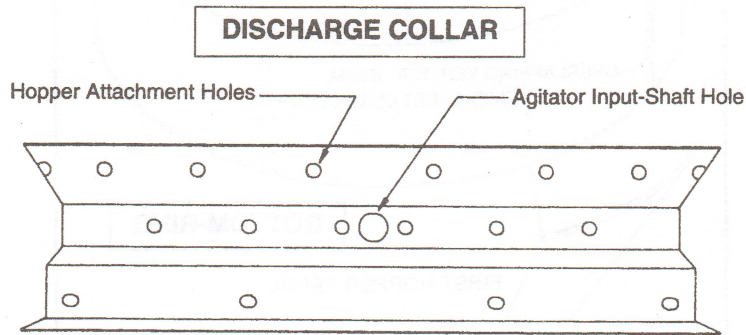

EXHIBIT N

Wipe down the inside bottom lip of the hopper panels and the portion of the discharge collar to which the hopper panels will attach. Apply a bead of caulk along both edges of the hopper attachment holes in the discharge collar (see EXHIBIT N). Insert the discharge collar into the bottom end of the hopper and align the agitator input shaft hole so that it will be centered directly between a pair of legs, away from the ladder and opener.

Situating the discharge collar in this manner will aid in the installation of an agitation device should you require one.

Use the agitator input shaft hole block-off plate, supplied with the discharge collar hardware, if you are not using an agitation device at this time.

Use the 5/16" x 3/4" (.8cm x 1.9cm) slotted truss head bolts and 5/16" (.8cm) flange nuts supplied with the discharge collar to attach the collar to the hopper, bolt heads to the inside.

Now install the last hopper section, caulking and bolting as before.

HOPPER TIGHTENING SEQUENCE – Before tightening any hopper connections, first locate the four bolts in the hopper-to-body seam which line up with the four sets of mid-sheet leg holes, and remove (see EXHIBIT O). Legs will attach at these points later in the assembly.

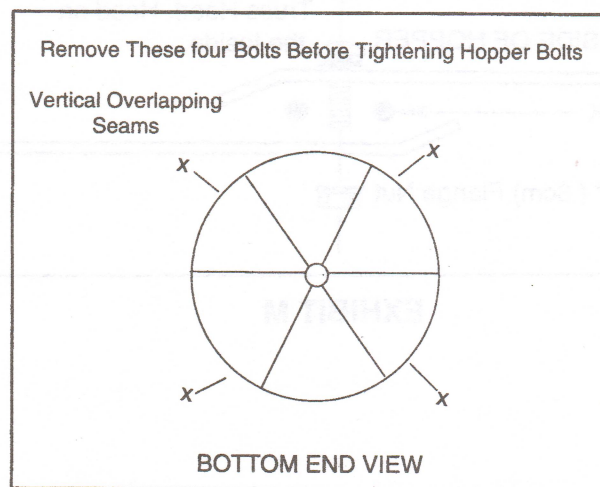

EXHIBIT O

STEP 6: LEG INSTALLATION – Locate six leg sections 92-9/16" (235.12cm) long.

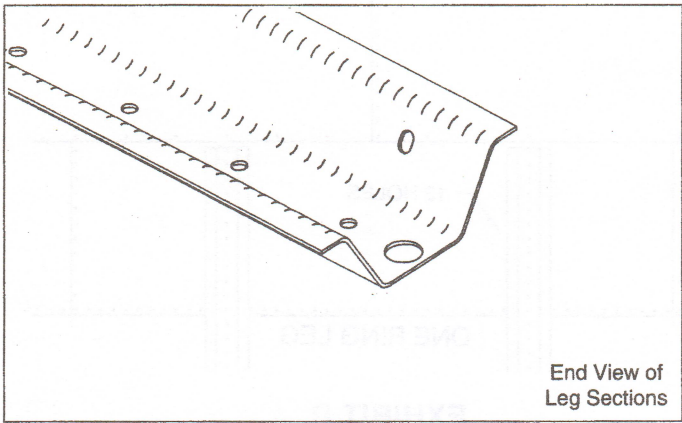

EXHIBIT P

Attach one leg anchor to the bottom of each leg assembly (see EXHIBIT Q) using three 5/16" x 1 1/4" (.8cm x 3.2cm) bolts and 5/16" (.8cm) hex nuts for each anchor.

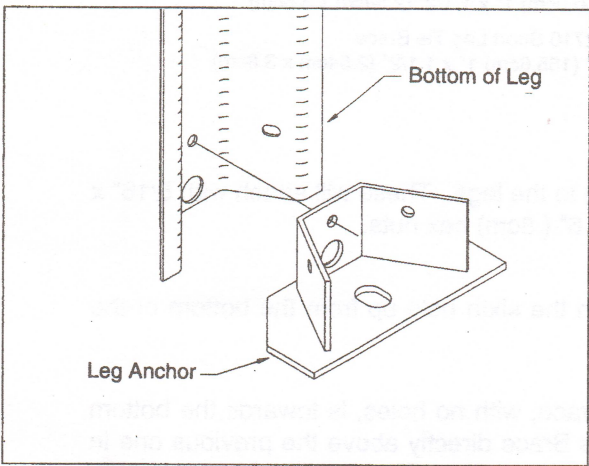
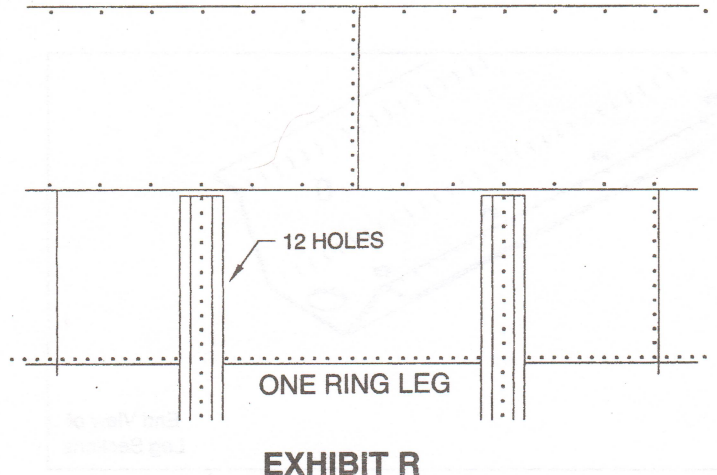

EXHIBIT Q

With the anchors attached to the legs, tighten all bolts in the leg assemblies at this time.

Attach the legs to the bin body. See EXHIBIT R. A leg assembly will attach at each bottom sidewall sheet in the mid sheet set of vertical holes. The legs will bolt up as shown in EXHIBIT R.



The legs will attach with 5/16" x 1 1/4" (.8cm x 3.2cm) bolts and 5/16" (.8cm) hex nuts, bolt heads to the inside. Do not tighten the leg attachment bolts yet. This will be done after the leg bracing is installed.

STEP 7: BRACING INSTALLATION – Locate 4 sections of Long Leg-Tie Bracing, 4 sections of Short Leg Tie Bracing and 8 sections of Leg-'X' Bracing (see EXHIBIT S).

Long Leg Tie Bracing goes between the legs adjacent to where the ladder will attach and then on the opposite side. The short braces go on the remaining two sides.

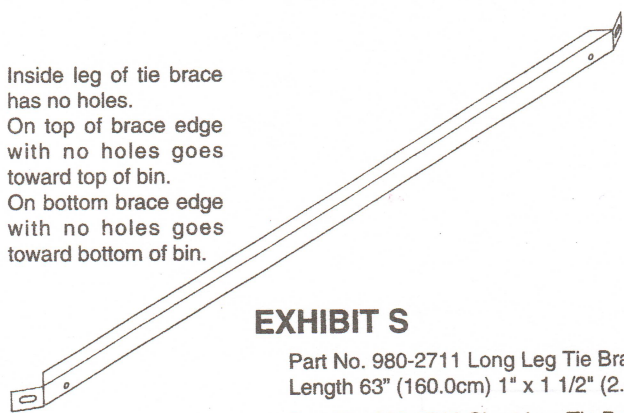

Inside leg of tie brace has no holes. On top of brace edge with no holes goes toward top of bin. On bottom brace edge with no holes goes toward bottom of bin.

EXHIBIT S

- Part No. 980-2711 Long Leg Tie Brace
Length 63" (160.0cm) 1" x 1 1/2" (2.54cm x 3.8cm)
- Part No. 980-2710 Short Leg Tie Brace
Length 61 1/4" (155.6cm) 1" x 1 1/2" (2.54cm x 3.8cm)

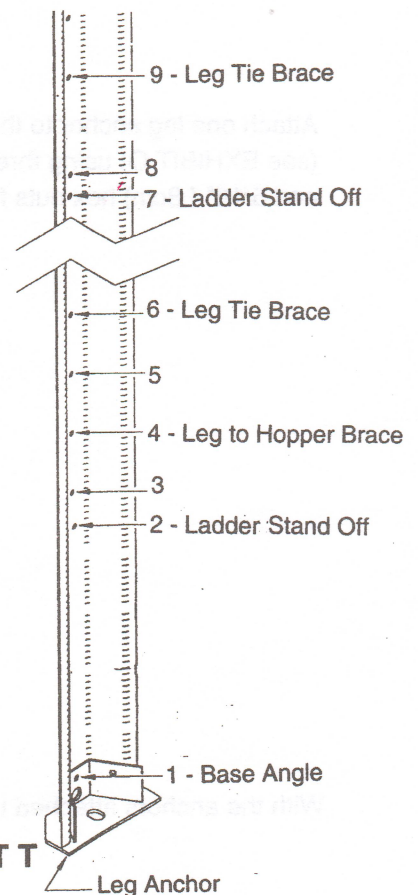
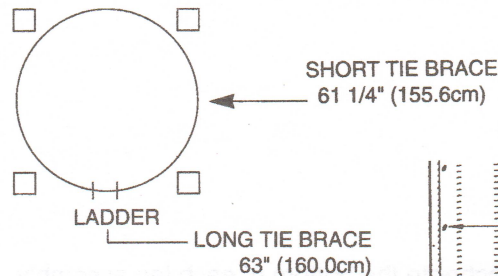

Start attaching the Leg-Tie Bracing to the legs. These will attach with 5/16" x 1 1/4" (.8cm x 3.2cm) bolts and 5/16" (.8cm) hex nuts.

The first Leg-Tie Brace attaches in the sixth hole up from the bottom of the leg (see EXHIBIT T).

Make sure the inside leg of this brace, with no holes, is towards the bottom of the bin. Attach another Leg-Tie Brace directly above the previous one in the 9th hole up from the bottom of the leg (see EXHIBIT T). Make sure the inside leg of this brace, with no holes, is towards the top of the bin. Continue installing Leg-Tie Bracing around the entire bin.

EXHIBIT T

Now begin attaching the Leg 'X' Bracing to the Leg-Tie Bracing (see EXHIBIT U).

Leg 'X' Bracing will attach using 5/16" x 3/4" (.8cm x 1.9cm) bolts and 5/16" (.8cm) hex nuts.

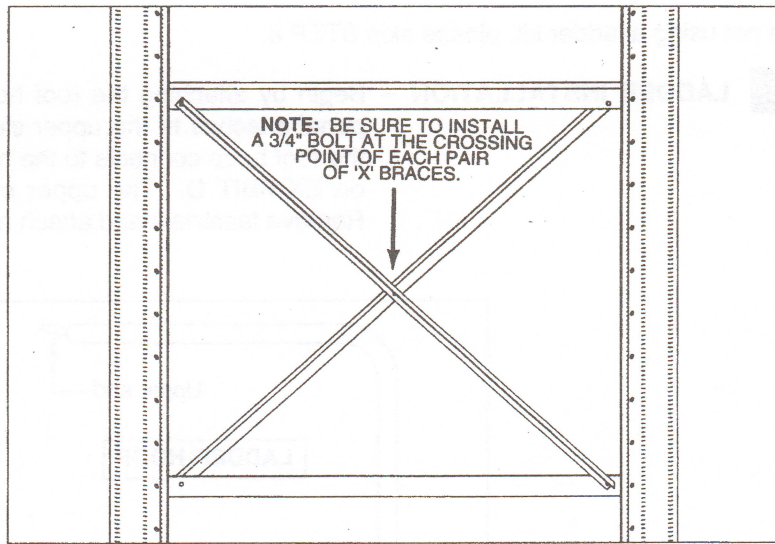
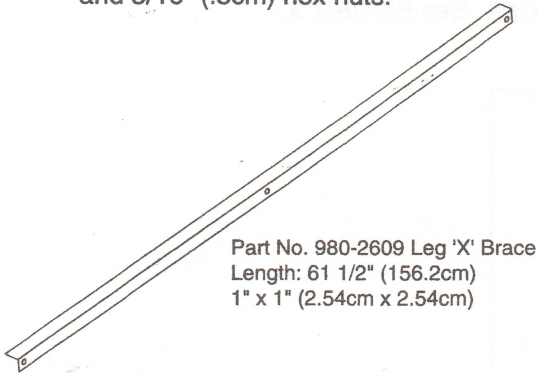

EXHIBIT U

INSTALL LEG BRACING: – The end of the leg to hopper brace with the round hole will attach to the leg in the hole just below the bottom Leg-Tie Brace connection with a 5/16" x 3/4" (.8cm x 1.9cm) bolt and 5/16" (.8cm) hex nut. The end of the brace with the slot attaches to the hopper-to-discharge collar. (see EXHIBIT V and W)

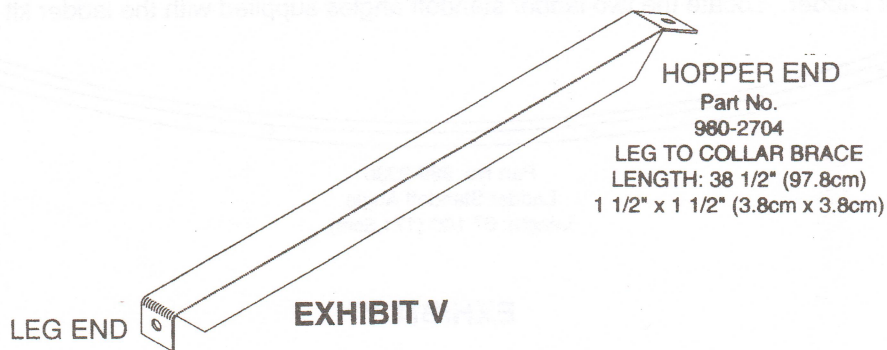

EXHIBIT V

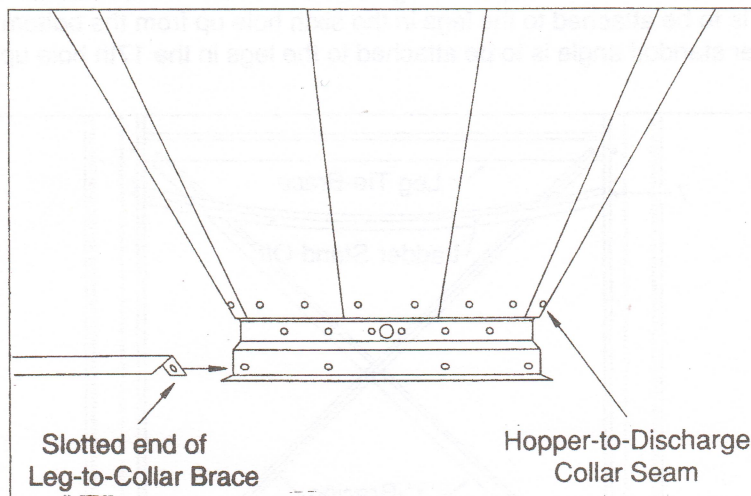

EXHIBIT W

With all of the Leg-Tie Bracing, Leg-'X' Bracing and Leg-to-Hopper Bracing installed, begin tightening all leg and bracing connections.

First tighten all bolts that attach the legs to the bin body, from the nut side ONLY.

Next tighten the hopper-to-discharge collar seam, from the nut side.

Next tighten all Leg-Tie Bracing connections. And last, tighten all Leg-'X' Bracing connections.

NOTE: DOUBLE CHECK ALL CONNECTIONS TO MAKE SURE ALL BOLTS HAVE BEEN TIGHTENED SECURELY.

If you are not using a ladder kit, please skip STEP 8.

STEP 8: LADDER INSTALLATION – Begin by attaching the roof hoops to the roof. Where the first roof panel attaches to the upper sidewall sheet, the lower straight end of the roof hoop connects to the holes marked “hoop” -- holes 23 and 35 on EXHIBIT D. The upper end attaches to the roof panel seam. Remove fasteners and attach hoops. See EXHIBIT X.

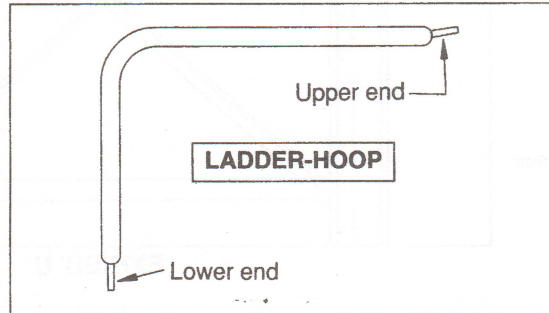

EXHIBIT X

Assemble Sidewall Ladder. Locate the two ladder standoff angles supplied with the ladder kit (see EXHIBIT Y)



Part No. 989-2330
Ladder Standoff Angle
Length: 67 1/2" (171.5cm)

EXHIBIT Y

These two standoff angles will be mounted to the pair of legs between which the roof ladder is centered. The bottom ladder standoff angle is to be attached to the legs in the sixth hole up from the bottom of the leg (see EXHIBIT Z). The upper ladder standoff angle is to be attached to the legs in the 17th hole up from the bottom of the leg (see EXHIBIT Z).

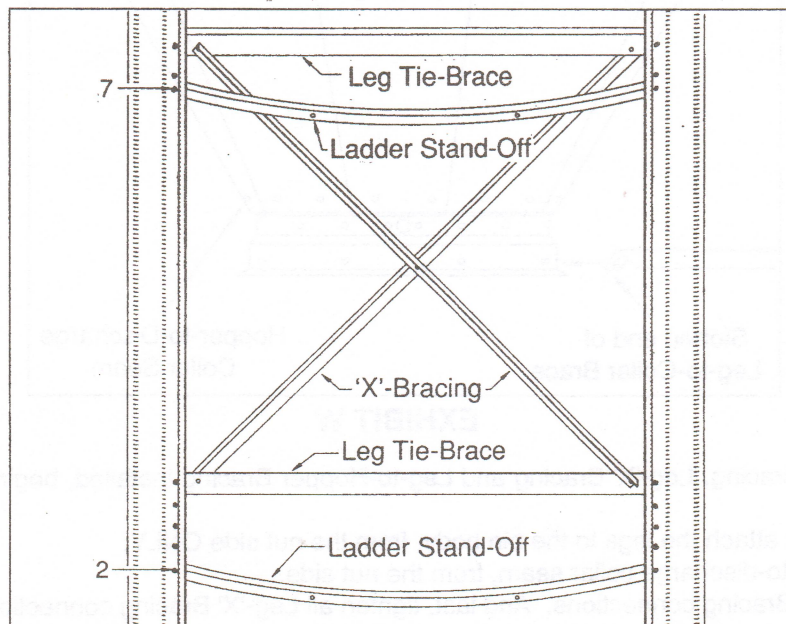

EXHIBIT Z

These standoff angles will attach to the legs using 5/16" x 1" (.8cm x 2.54cm) bolts and 5/16" (.8cm) hex nuts.

Now finish attaching the body ladder. Each body ladder section is the same height as the body sheet to which it will be attached. The mounting tabs at the top of the body ladder mount directly on top of the mounting tabs at the bottom of the roof ladder. Use 5/16" x 1 1/4" (.8cm x 3.2cm) bolts and 5/16" (.8cm) hex nuts at the roof ladder/body ladder overlap, making sure to place the rubber backing washer inside the bin wall under the hex nut. This connection will be tightened from the bolt-head end to prevent damage to the rubber seal.

All ladder connections will use 5/16" x 1 1/4" (.8cm x 3.2cm) bolts and 5/16" (.8cm) hex nuts.

With all of the ladder sections in place, tighten all bolts which attach the ladder to the bin, as well as the bolts which attach the ladder standoff angles to the legs. Double check all ladder related connections to make sure all are tightened securely.

STEP 9: Assemble lid and lid opener kit. Follow the directions included with the kit.

STEP 10: SET BIN UPRIGHT – Now it is time to prepare for setting the bin upright. First cut 2" x 4" or 4" x 4" lumber to fit securely between the pair of legs that will first touch the ground and the pair of legs directly above them (see EXHIBIT A-1).

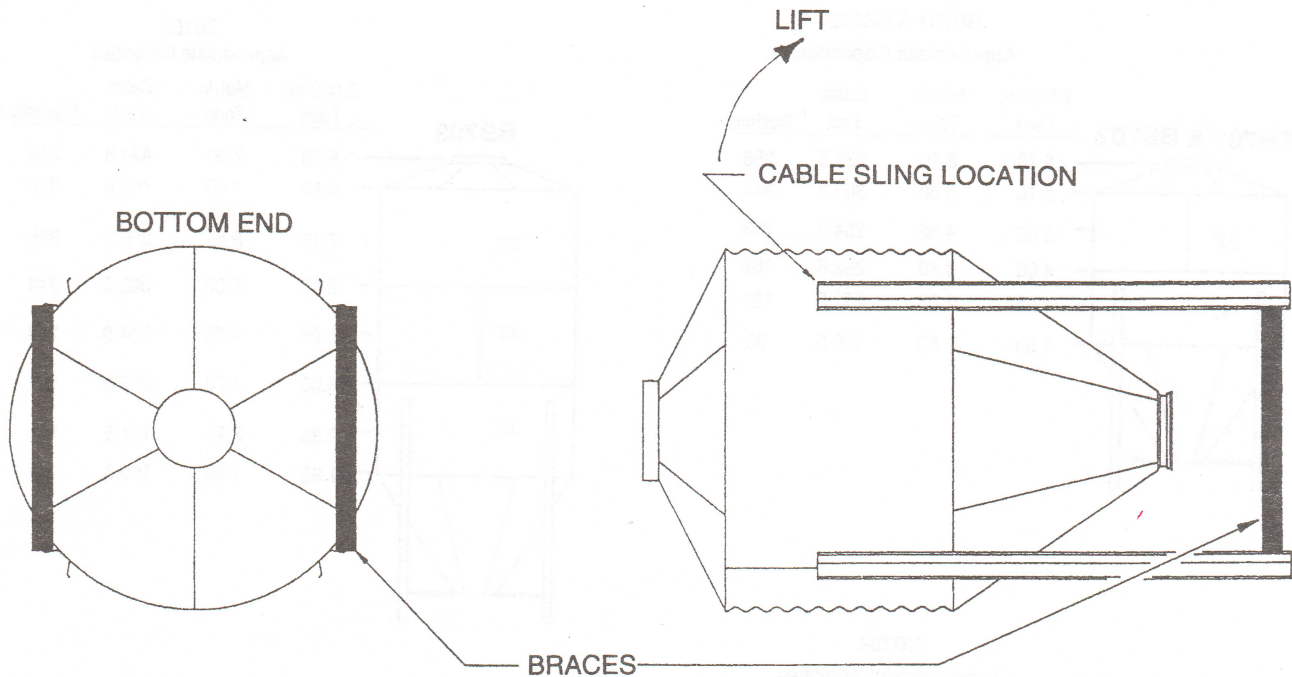

EXHIBIT A-1

Now, using a crane with a sling, cable or chain around the bin body at the top of the legs, very carefully raise the bin to the standing position.

STEP 11: BIN ANCHORING – Before anchoring the bin to the foundation, measure between opposite legs of the bin. This distance must be approximately 92 9/32" (234.4cm). This distance can vary as much as 3/8" (.95cm) due to whether or not the legs are mounted on an overlapping body vertical seam.

Make sure the bin is level. Use shims under the leg anchors as necessary.

When drill in type anchors are used, they must be 5/8" (1.6cm) diameter and have a minimum embedded length of 7" (17.8cm).

STEP 12: BIN GROUNDING – Each bin must have two (2) grounding connections around the circumference of the bin. This equipment is to be purchased locally.
Cables can be run through a PVC sleeve set in the slab during construction.

⚠ CAUTION ⚠
Have a qualified electrician check to be sure all equipment is installed and grounded according to all applicable national and local codes.

NOTICE
All hopper-bottom bins are designed for the storage of free-flowing materials only. Soybean meal, meat scraps, and certain other materials are **not** considered free-flowing and should not be stored in these bins.

EXHIBIT B-1 Chart of Capacities

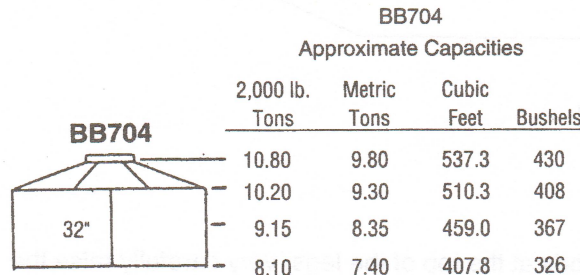
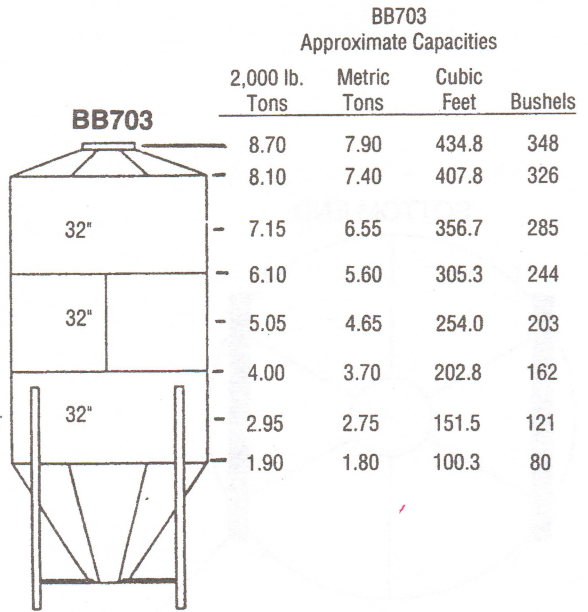
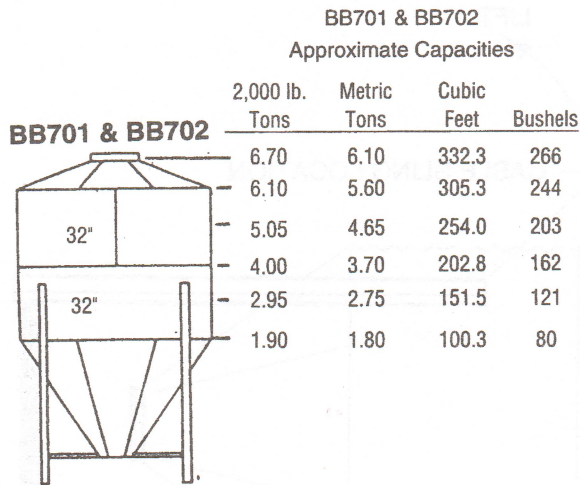

HOPPER BOTTOM BIN CAPACITIES

MODEL NO.	APPROXIMATE CAPACITIES			Bushels
	2000 lb. Tons	Metric Tons	Cubic Feet*	
BB701	4.60	4.20	229.8	184
BB702	6.70	6.10	332.3	266
BB703	8.70	7.90	434.8	348
BB704	10.80	9.80	537.3	430

*40 pounds per cubic foot

All capacities are approximate. Capacities are calculated using 40 pounds per cubic foot; 50 pounds per bushel.

EXHIBIT C-1

Height Specifications

'A' = Discharge Collar Height - Inches (cm)
'B' = Overall Bin Height - Feet (Meters)

MODEL NUMBER	A	B
BB701	26 1/2" (67.3cm)	13' 10 1/2" (4.23m)
BB702	26 1/2" (67.3cm)	16' 6 1/2" (5.04m)
BB703	26 1/2" (67.3cm)	19' 2 1/2" (5.85m)
BB704	26 1/2" (67.3cm)	21' 10 1/2" (6.67m)

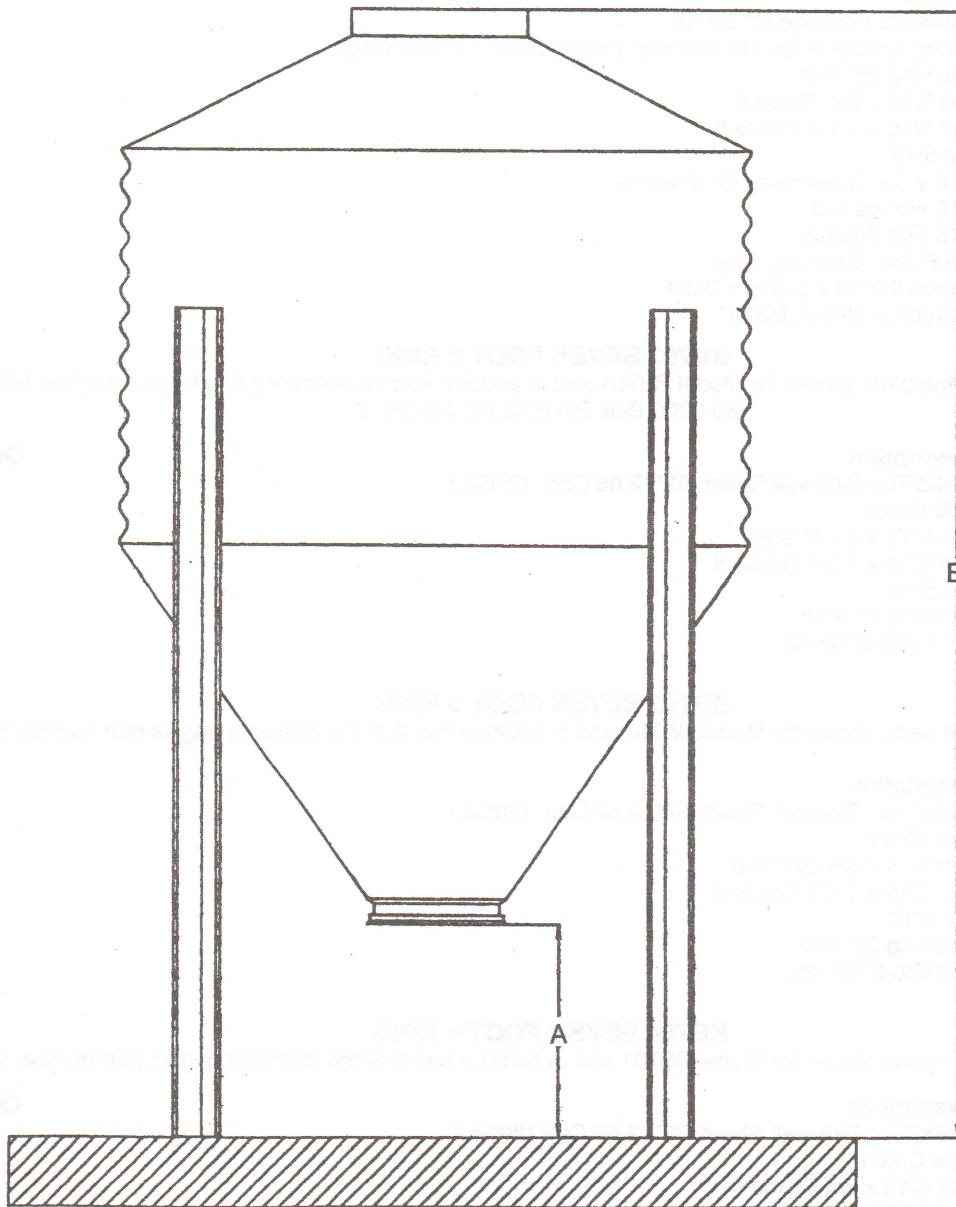

**BILLS OF MATERIAL/REPAIR PARTS LIST
SEVEN (7) FOOT DIAMETER HOPPER BOTTOM BIN
NARROW CORRUGATION (2.66" – 6.76CM)**

BB701 SEVEN FOOT 1 RING

Part No.	Description	Quantity
980-2701	7' Roof Section (22 Ga.)	6
980-2702	7' Hopper Section (18 Ga.)	6
980-2708	7' Bottom Sidewall Sheet, 32" 2.66 Corr. (18 Ga.)	2
950-1467	Bin Leg, 139.25"	4
980-2704	Leg to Collar Brace (12 Ga.), 38.5"	4
980-2710	Short Leg Tie Brace (12 Ga.), 61.25"	4
980-2711	Long Tie Brace (12 Ga.), 63"	4
980-2609	Leg 'X' Brace (12 Ga.), 61.5"	8
319052	Collar Assembly w/bolts	1
311209	Ftl Lid Assy. w/collar	1
312976	Ftl. Chain Kit	1
311214	Bulk Chain	60"
43814	S Hook	4
980-2714	Hardware package for BB701	1
950-1205	4" Leg Anchor Bracket Assembly (foot at bottom of each leg)	4
907-0051	Caulking 25' Roll	8
907-0612	Bolt 5/16 x 3/4 Grade 5	78
907-0619	Bolt 5/16 x 1 1/4 Grade 5	360
907-0613	Nut 5/16	300
907-8001	5/16 x 3/4 Truss Head Gr. 8 w/seal	126
907-8002	5/16 Flange Nut	264
OF121	5/16 Flat Washer	2
980-2625	Dbl Pulley Mounting Strip	2
UA1-C	Carton 9 3/16 x 9 3/16 x 3 3/4	1
ISHBB7N	Instruction Sheet, BB701	1

BB702 SEVEN FOOT 2 RING

Model BB702 has all the parts shown for Model BB701 and in addition has the following ring kit part number 980-2709.
980-2709 Bulk Bin Ring Kit, Narrow 7'

Part No.	Description	Quantity
980-2707	7' Mid/Top Sidewall Sheet, 32", 2.66 Corr. (20Ga.)	2
311214	Bulk Chain	64"
907-0612	Bolt 5/16 x 3/4 Grade 5	28
907-0619	Bolt 5/16 x 1 1/4 Grade 5	22
907-0613	Nut 5/16	50
907-0051	Caulking 25' Roll	2

Quantities shown are for 1 980-2709 Kit

BB703 SEVEN FOOT 3 RING

Model BB702 has all the parts shown for Model BB701 and in addition has 2 of the following ring kit part number 980-2709.

Part No.	Description	Quantity
980-2707	7' Mid/Top Sidewall Sheet, 32", 2.66 Corr. (20Ga.)	4
311214	Bulk Chain	128"
907-0612	Bolt 5/16 x 3/4 Grade 5	56
907-0619	Bolt 5/16 x 1 1/4 Grade 5	44
907-0613	Nut 5/16	100
907-0051	Caulking 25' Roll	4

Quantities shown are for 2 980-2709 kits.

BB704 SEVEN FOOT 4 RING

Model BB704 has all the parts shown for Model BB701 and in addition has 3 of the following ring kit part number 980-2709.

Part No.	Description	Quantity
980-2707	7' Mid/Top Sidewall Sheet, 32", 2.66 Corr (20Ga.)	6
311214	Bulk Chain	192"
907-0612	Bolt 5/16 x 3/4 Grade 5	84
907-0619	Bolt 5/16 x 1 1/4 Grade 5	66
907-0613	Nut 5/16	150
907-0051	Caulking 25' Roll	6

Quantities shown are for 3 980-2709 kits.

BB705 SEVEN FOOT 5 RING

Model BB705 has all the parts shown for Model BB701 and in addition has 3 of the following ring kit part number 980-2709.

Part No.	Description	Quantity
980-2707	7' Mid/Top Sidewall Sheet, 32", 2.66, (20Ga.)	6
311214	Bulk Chain	256"
907-0612	Bolt 5/16 x 3/4 Grade 5	84
907-0619	Bolt 5/16 x 1 1/4 Grade 5	66
907-0613	Nut 5/16	150
907-0051	Caulking 25' Roll	6

Quantities are for 3 980-2709 kits.

Model BB705 also has a second ring kit which is 18 gauge material, kit part number 980-2731. This kit goes in the position second ring from the bottom. 980-2731 Hopper Bin Second Ring Kit, Narrow, 7"

Part No.	Description	Quantity
980-2715	7' Mid/Top Sidewall Sheet, 32", 2.66, (18Ga.)	2
907-0612	Bolt 5/16 x 3/4 Grade 5	28
907-0619	Bolt 5/16 x 1 1/4 Grade 5	22
907-0613	Nut 5/16	50
907-0051	Caulking 25' Roll	2

LADDER KITS FOR SEVEN (7) FOOT HOPPER BOTTOM BINS

Part No.	Description	Quantity				
		1 Ring BBL701	2 Ring BBL702	3 Ring BBL703	4 Ring BBL704	5 Ring BBL705
988-1000	Outside Ladder Assy., 4" Corr., 44" long	2	2	2	2	2
988-1001	Outside Side Rail, 4" Corr., 44" long	4	4	4	4	4
988-1002	Ladder Rung	8	8	8	8	8
907-9050	5/16-18 x 1 1/2 Carr. Bolt, plated	16	16	16	16	16
907-0613	Nut 5/16	16	16	16	16	16
988-1010	Outside Ladder Assy, 2 2/3" Corr, 33" long	1	2	3	4	5
988-1011	Outside Side Rail, 2 2/3" Corr., 33" long	2	4	6	8	10
988-1002	Ladder Rung	3	6	9	12	15
907-9050	5/16-18 x 1-1/2 Carr. Bolt, plated	6	12	18	24	30
907-0613	Nut 5/16	6	12	18	24	30
989-2330	Ladder Stand-Off Angle, 67 1/2"	2	2	2	2	2
989-2331	Ladder Hoop, 7' Hopper Bin	2	2	2	2	2

WARRANTY

WARRANTY

The manufacturer warrants that the material and workmanship of the product are in accordance with the specifications and standards set forth in the product literature. The manufacturer shall not be liable for damages, including consequential damages, of any kind or nature, whether direct or indirect, arising out of the use of the product, even if such damages are foreseeable. The manufacturer's obligation under this warranty is limited to the repair or replacement of the product, at the manufacturer's option, and shall not include the cost of labor, transportation, or any other charges. This warranty is void where prohibited by law. The manufacturer's liability under this warranty is limited to the original purchase price of the product. This warranty is in full satisfaction of all other warranties, express or implied, that may apply to the product. The manufacturer makes no representation or warranty regarding the fitness of the product for any particular use or application. The user of the product shall be responsible for determining the appropriate use and application of the product. The manufacturer shall not be liable for any damages, including consequential damages, of any kind or nature, whether direct or indirect, arising out of the use of the product, even if such damages are foreseeable. This warranty is void where prohibited by law. The manufacturer's liability under this warranty is limited to the original purchase price of the product. This warranty is in full satisfaction of all other warranties, express or implied, that may apply to the product. The manufacturer makes no representation or warranty regarding the fitness of the product for any particular use or application. The user of the product shall be responsible for determining the appropriate use and application of the product. The manufacturer shall not be liable for any damages, including consequential damages, of any kind or nature, whether direct or indirect, arising out of the use of the product, even if such damages are foreseeable. This warranty is void where prohibited by law. The manufacturer's liability under this warranty is limited to the original purchase price of the product. This warranty is in full satisfaction of all other warranties, express or implied, that may apply to the product. The manufacturer makes no representation or warranty regarding the fitness of the product for any particular use or application. The user of the product shall be responsible for determining the appropriate use and application of the product.

FIELD MODIFICATIONS AND MAINTENANCE

Our HSPI bin is a low maintenance product when used as described. In all cases there is maintenance or modification required as the bin ages. We recommend these be done as soon as the need arises. A scheduled maintenance program on all your equipment is recommended to maintain a quality facility.

1. The anchor bolts are an important structural component. Make sure they stay clean of debris and moisture to reduce corrosion.
 2. Tighten the anchor bolts anytime they show signs of being loose.
 3. Any caked material in the hopper should be cleaned by mechanical brushing either dry or high pressure wet system. This should be done by access through the discharge collar.
 4. Reseal any area where there is a sign of leaking or moisture.
 5. Galvanize will age and turn dark which is normal but any white or red rust needs to be cleaned and treated to prevent major damage.
 - Red rust should be treated by wire brushing, cleaning, and painting with a good rust inhibitor, then paint with a galvanize paint.
 - White rust should be rubbed down with cleaner (diesel fuel, white vinegar). Then washed off with water.
- At the first sign of deterioration (rust, cracks, etc.) replace ladders, or any other weight bearing parts. DO NOT PAINT OVER THESE.
6. Any field modifications that affect the structural stability of the bin or create a possible hazard must be approved in writing by an authorized representative from the manufacturer.
 7. Be absolutely sure all shields and guards are replaced after doing maintenance to belts, chains, or any other moving parts.
 8. At any time large cracks appear or any type of chipping or flaking of the concrete occur, contact your dealer for ways to repair these areas before they become a serious threat to the stability of your bin.

WARRANTY

Hawkeye Steel Products, Inc. (HSPI) warrants its hopper bottom bins to be free from defects in material or workmanship for one year from the date of initial installation by the original purchaser. If such a defect is found by HSPI to exist within the one year period, HSPI will, at its option, (a) repair or replace such product free of charge, F.O.B. the factory of manufacture, or (b) refund to the original purchaser the original purchase price, in lieu of such repair or replacement.

CONDITIONS AND LIMITATIONS

1. This product must be purchased from and installed by an authorized HSPI dealer or one of its certified representatives or the warranty will be void.
2. The product must be installed and operated in accordance with instructions published by HSPI or warranty will be void.
3. Malfunctions or failure resulting from misuse, abuse, negligence, alteration, accident, or lack of proper maintenance shall not be considered defects under this warranty.
4. HSPI bins are designed for grains and/or free flowing materials and are not warranted for other distribution or substances. Other use will void warranty.

HSPI shall not be liable for any consequential or special damage which any purchaser may suffer or claim to suffer as a result of any defect in the product. "Consequential" or "special damages" as used herein include but are not limited to lost or damaged products or goods, costs of transportation, lost sales, lost orders, lost income, increased overhead, labor and incidental costs and operational inefficiencies.

THIS WARRANTY CONSTITUTES HSPI'S ENTIRE AND SOLE WARRANTY AND HSPI EXPRESSLY DISCLAIMS ANY AND ALL OTHER WARRANTIES, INCLUDING BUT NOT LIMITED TO EXPRESS AND IMPLIED WARRANTIES AS TO MERCHANTABILITY, FITNESS FOR PARTICULAR PURPOSE SOLD AND DESCRIPTION OR QUALITY OF THE PRODUCT FURNISHED HEREUNDER.

Any exceptions to this warranty must be authorized in writing by an officer of the company. HSPI reserves the right to change models and specifications at any time, without notice or obligation.